 Equilibratrice portatile per ruote da camion e autobus. Montabile su qualsiasi tipo di smontagomme da auto-carro a mandrino Particolarmente adatta al servizio mobile e a chi ha poco spazio in officina

 *Portable wheel balancer for truck and bus wheels. Can be mounted on any type of spindle-operated truck tyre changer. Particularly suitable for mobile service and for those who have little room in the workshop.*



Completa di supporto per l'alloggiamento dell'unità di misura, visualizzatore display e kit di centraggio

Complete with support for housing the measuring unit, display and centring kit

Display ad ancoraggio magnetico, alimentato a batterie ricaricabili.

Magnetically fixed display, powered with rechargeable batteries and easy to use.

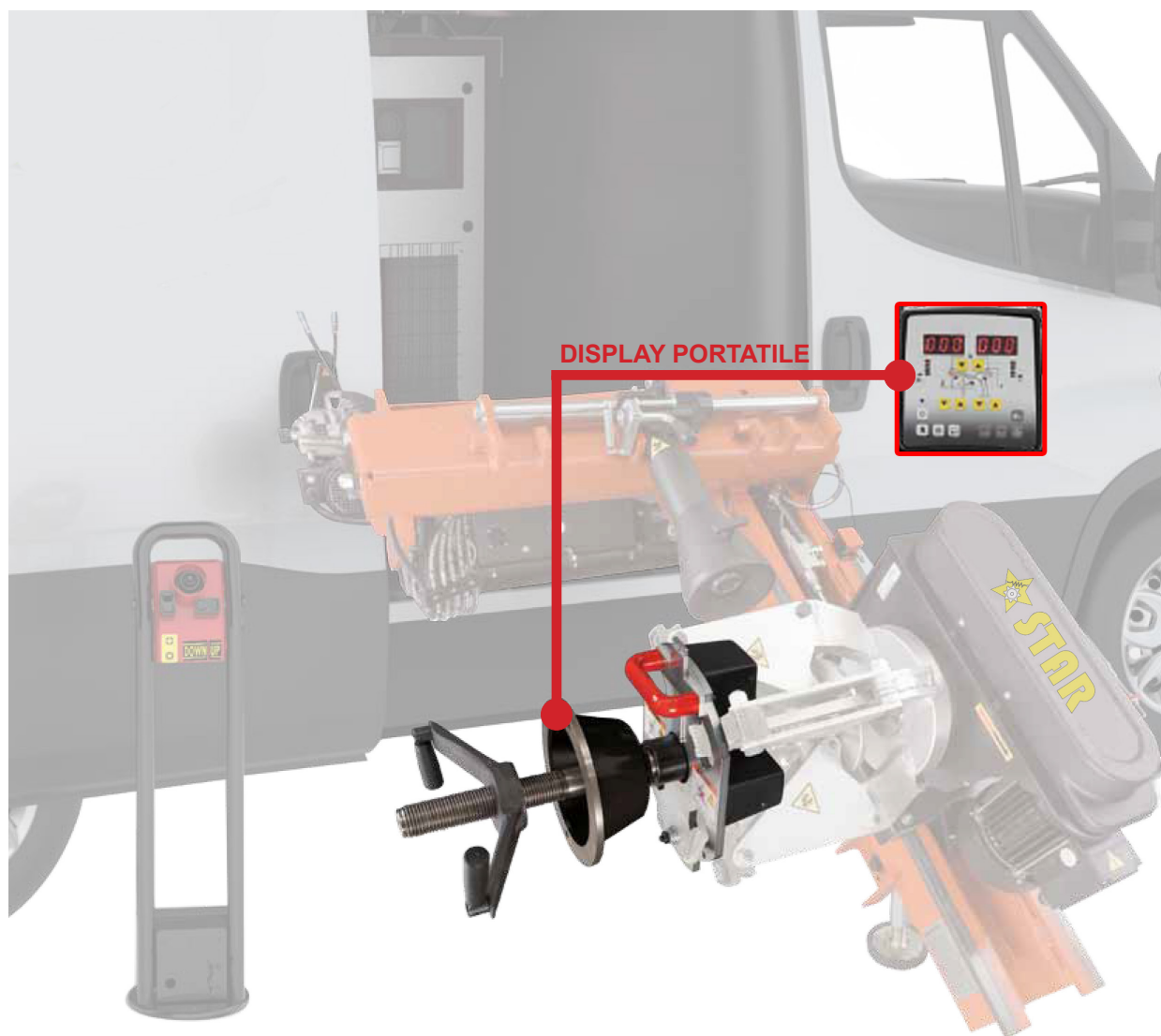

DISPLAY PORTATILE

Caratteristiche principali / Main features

- **Equilibratrice compatta e leggera.**
- **Dimensioni e peso contenuti** facilitano la movimentazione e l'utilizzo.
- **Sistema di montaggio semplice e veloce** su qualsiasi tipologia di smontagomme camion.
- Ideale per il **servizio mobile** e chi ha poco spazio in officina.
- **Bassa velocità di rotazione.**
- **Lancio ed inserimento dimensioni ruota manuale.**
- **Resistente agli agenti atmosferici grazie alla protezione IP41.**
- Completa di **tutti i programmi di equilibratura: Dinamica, Statica e ALU** per cerchi in lega.

- **Compact and light wheel balancer.**
- **Small size and weight facilitate movement and use.**
- **Easy and quick mounting system** on any type of truck tyre changer.
- **Suitable for mobile service** and for those who have little room in the workshop.
- **Low rotation speed.**
- **Manual wheel size launch and entry.**
- **Weather-resistant** thanks to IP41 protection.
- **Complete with all balancing programs:** Dynamic - Static and ALU for alloy rims.

Accessori / Accessories



Dati tecnici / Technical data

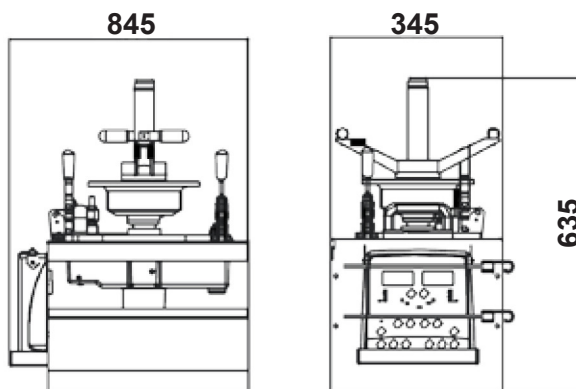

Alimentazione / Power Supply	12Vdc - 115/230 Vac - 50/60Hz - 0,018 kW
Classe di protezione / Protection rating	IP41
Diametro albero / Shaft diameter	40 mm
Tempo di ciclo per ruota / Cycle time for wheel	8 / 20 s
Velocità di equilibratura / Balancing speed	< 70 rpm
Incertezza misura / Measurement uncertainty	10 g
Rumorosità media / Average noise	< 70 dB (a)
Larghezza cerchio impostabile / Settable rim width	1,5" / 20" (40 / 510 mm)
Diametro impostabile / Settable diameter	10" / 30" (265 / 765 mm)
Peso massimo ruota / Maximum wheel weight	< 250 kg
Peso macchina / Machine weight	~ 20 kg